



SAVAGE
BROS. CO.
S I N C E 1 8 5 5

1125 Lunt Avenue
Elk Grove Village, IL 60007-5023 USA

Phone: 847-981-3000
USA Fax: 800-2-SAVAGE
World Fax: +847-981-3010

E-mail: info@savagebros.com
Web: www.savagebros.com

A 21st Century Company... with 19th Century Craftsmanship

50 lb/20 kg Table-Top Chocolate Depositor with PLC Touch Screen Control

Depositing
Nozzle

Heated
Depositing Pipe

Water-Jacketed
stainless steel
tank

Depositing
Pump



PLC Touch Screen Controls
Feature Depositing Pump
Control in addition to Melting,
Cooling, & Tempering cycles
(as applicable to model)



12 RPM sweeping agitator,
Removable without tools for
easy cleaning!

Two models to choose from:

- #1434-40 Melter/Conditioner Mini-Depositor
- #1434-60 Auto-Temperer Mini-Depositor

- 50 lb / 20 kg melted capacity all stainless steel construction water-jacketed tank
- PLC Touch-Screen controller
- Water-jacketed draw off valve for plug-free operation
- Removable lid for easy loading
- 12 RPM sweep agitator with bottom drive gearmotor
- Mini-Pump Depositor mounted to draw off valve
- Fixed volume stroke up to 3 oz per cycle
- Variable volume deposit
- Depositor controlled with foot pedal cycle switch or interval timer for automatic mode
- Mold filling nozzle with electrically heated pipe
- Special nozzles for specific applications are available
- 110V 60Hz or 220V 50Hz and compressed air source required



Knob-top Lid

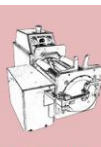

Gas & Electric Stoves ♦ Copper & Stainless Kettles ♦ FireMixer Cooker-Mixers ♦ Carousel Line ♦ Bowl & Kettle LIFT/Trucks ♦ Cooling Tables ♦ Chocolate Tempering ♦ Depositing & Transfer Systems

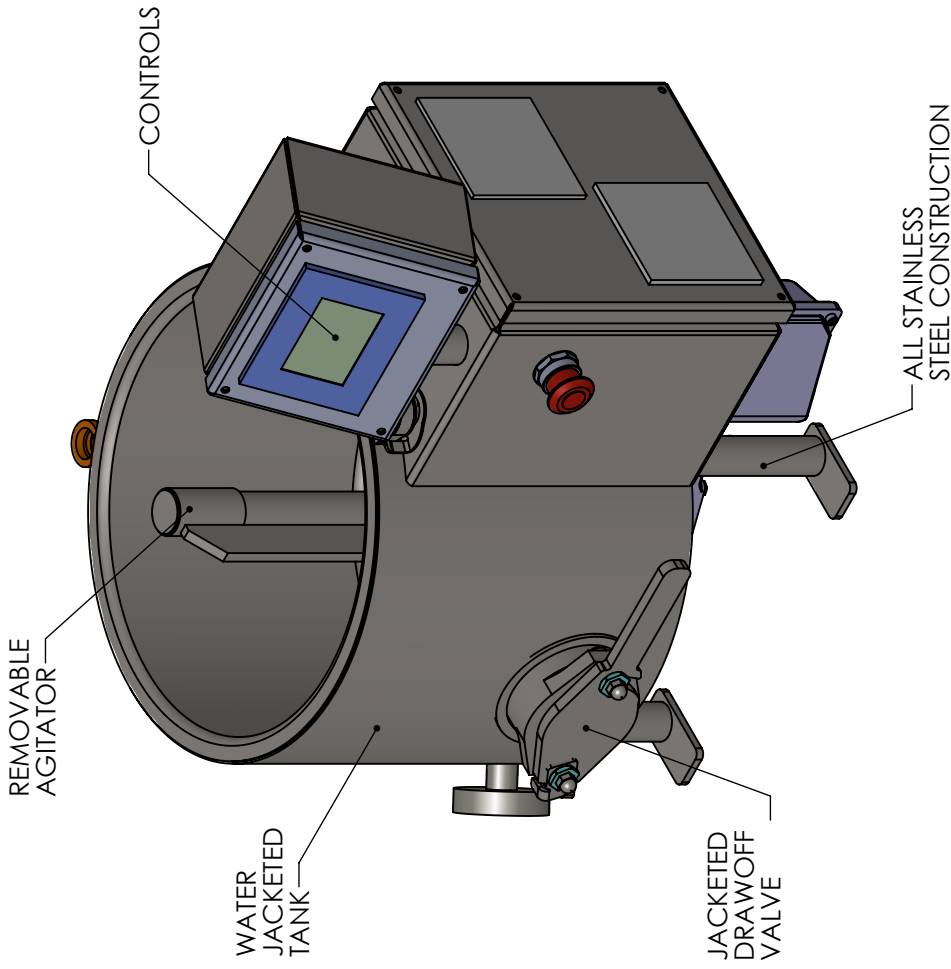
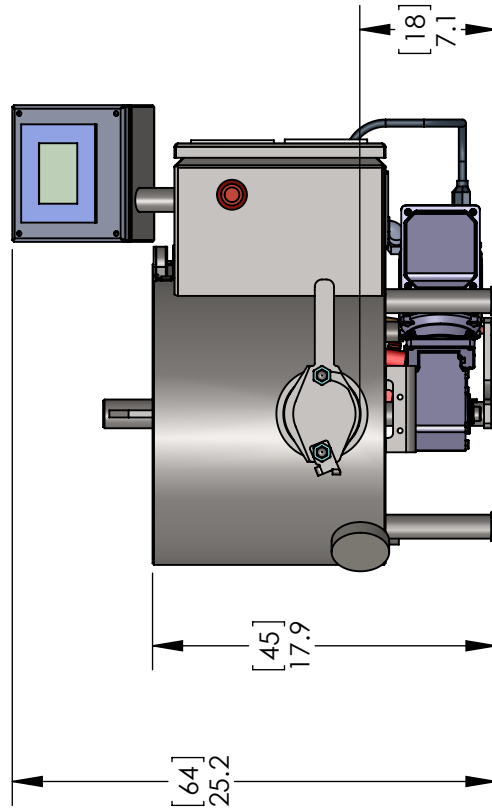
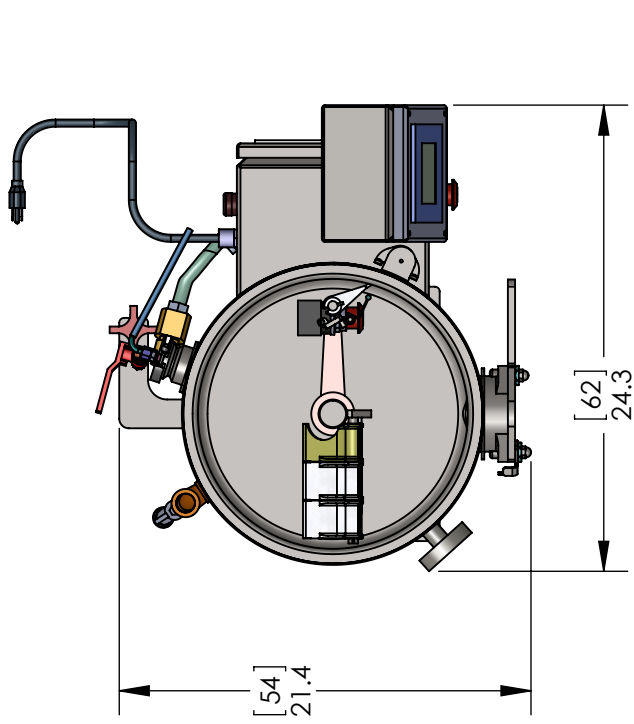

UNITS: [CENTIMETERS]
[INCHES]

DO NOT SCALE DRAWING

QUOTATION

FOR QUOTATIONAL PURPOSES
ONLY

ALL DESIGNS SUBJECT TO
FINAL APPROVAL BEFORE
MANUFACTURE

UNLESS OTHERWISE SPECIFIED
ALL DIMENSIONS ARE INCHES

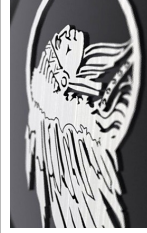

SAVAGE BROS. CO.
1125 W. Lunt Ave
Elk Grove Village, IL 60007 U.S.A.
Phone: (847) 981 - 3000
USA Fax: (800) 2 - SAVAGE
World Fax: (847) 981 - 3010

50LB CHOCOLATE MELTER
OVERALL DIMENSIONS

DWG. NUM. SD-0934-60

DRAWN BY

ML

DATE

03.06.12

SCALE

SCALE: 1:10

SHEET

1 OF 1